



Installation Instructions

6718 Whitestone Road • Gwynn Oak, Maryland 21207 • (410) 298-4343
FAX: (410) 298-3579 • www.atiracing.com

ATI Super Damper – Jr Flywheel Part #s: 917163 - 917164 - 917165 - 917172 - 917155

Congratulations on the purchase of your new ATI Super Damper designed for Junior Dragster and other Briggs & Stratton based flathead engines. The benefits of a properly tuned and functioning crankshaft harmonic balancer have been proven over and over for more than 100 years, and ATI has finally provided that benefit for the Briggs & Stratton platform.

Your new ATI Super Damper bolts have come with blue 242 Loctite installed and torqued to 18 ft lbs, and is set at zero degrees. If you are replacing a non adjustable flywheel, simply bolt your new Super Damper on and you will have the same timing.

Timing Adjustments

Timing changes are done in + or – 2 deg increments using the supplied 1/8th inch dowel pin. Simply loosen the bolts, move the magnet part of the damper adjust till the hole in the shell lines up with the hole in the hub, insert your dowel pin to keep anything from moving, reapply blue Loctite and torque the bolts down evenly in a non-circular pattern to 18 ft lbs. 1-degree increment changes can be made with the smaller lines that are lasered on the hub and the shell.

Installation

Step 1. Remove your Flywheel

Remove your current, non-damped flywheel by removing the main bolt that is also used to start your engine. Sometimes some heat is needed to help loosen the Loctite if it has been used on the starter nut. **Be sure to only put heat directly where the thread is on the nut.** If your current flywheel has adjustable timing, please note the existing setting. You may or may not need a puller device to get your flywheel off. This device threads into 2 holes in the current flywheel and allows you to press against the end of the crankshaft, pulling on the flywheel so it breaks free of the taper lock.

Step 2. Prepare for Installation

You **MUST** run a woodruff key with the ATI Super Damper – Jr Flywheel. Be sure the taper, keyway and the rest of the crank is in clean order, with no nicks, or burrs. Use a permanent marker to make a line on the taper area that you can see and use in the next step.

Step 3. Install the Super Damper

Push the ATI damper in with some force and rotate it left and right on the taper so that it will remove or smudge the line you made. You want to see that at least 80% of the line on the taper has been smeared or removed. If it has, then you are ready to install. If it has not, then you need to get some lapping compound and repeat the process to help the ID of the ATI Super Damper conform to the ID of the crank taper.

Once the step above is done, be sure both parts are clean, and carefully install your key. Put your finger behind the damper while you slide it on to make sure the key stays in place.

Your starter nut can now get reinstalled with blue Loctite and torqued to your engine builders' specs. 55-65 ft lbs seems to be the consensus but its pretty hard to hold the flywheel and most people use a 1/2" impact and give it 2-3 impacts.

You are ready to get back to racing!

Junior Dragster Flywheel / Damper Advance Angle Adjustment

The advance angle of the Junior Dragster Flywheel Dampers may conveniently be adjusted in steps of 2° by loosening the bolts and lining up marked holes corresponding to the desired angle. The angle is then locked in place with an 1/8" dowel pin placed in the hole while tightening the bolts.

Odd advance angles (e.g. +1°, +3°) may also be locked in by the 1/8" dowel pin. This is done by placing the pin in the hole indicated in the chart below. Use the degree scale on the outside of the flywheel to get the angle close prior to placing the 1/8" dowel pin.

A pointed pick, similar to that shown below, can be used to move the flywheel 1° at a time (with bolts loosened.) Whenever a pin hole is lined up, there will be another that is about 1/2 hole mis-aligned. Place the point of the pick in this hole and carefully align the hole. Find the next hole that is 1/2 hole off and repeat the process until the desired angle is reached.

NOTE: Remove dowel pin after setting your timing!

Desired Advance	Hole Aligned
+7	0
+5	-2
+3	-4
+1	-6
-1	+6
-3	+4
-5	+2
-7	0

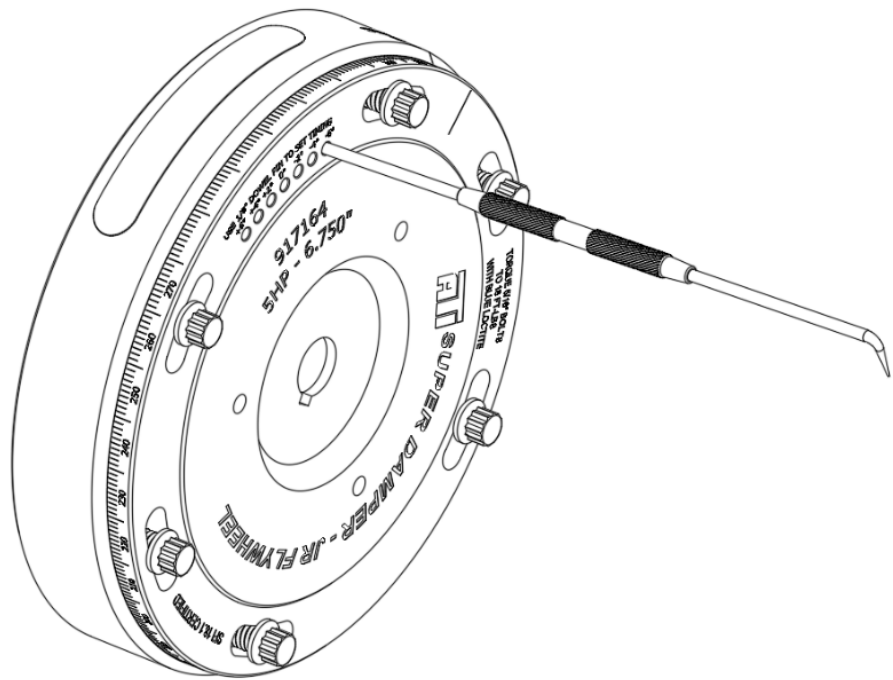

IMPORTANT INFORMATION!

***** See pages 7 and 8 for Warranty and Product Information!*****

CUSTOMERS MUST INSPECT ALL GOODS UPON ARRIVAL!

ATI must be notified of all claims for loss or damaged merchandise within 5 days of receipt. Contact us at 800-284-3433.

After receiving your order, please keep all packaging material until you are completely satisfied with the purchase. No returns of merchandise will be accepted without prior consent. Unless other arrangements are made with ATI, all freight must be insured and charges prepaid. Any returns for credit must be in new and resalable condition and in the original packaging. Loose bolts in the box will damage a damper!

Credit may be delayed or declined for items that are not packaged sufficiently and arrive damaged.

CAUTION! NEW BALANCING INFORMATION

6 Flat Head Screws should be installed with #242 (blue) Loctite and torqued as follows.

Allen Head: 16 ft/lbs Use a Torx 40 Plus.

Cap Screws: 28-32 ft/lbs

3 ferry cap screws can be used for pulley or trigger mounting but **MUST be installed and torqued if no pulleys are used.**

ON CHRYSLER DAMPERS:

Cap screws for pulley mounting are not supplied, but must be installed. Length of bolts must be 3/8" longer than stock. Bolt ends may be very close to the timing cover at the back of the damper hub. Bolts should not go through the damper hub with the pulley installed.

Torque 28-32 ft/lbs.

RECOMMENDED MAINTENANCE:

- Street and Drag Use (up to 800 HP): Every 10 years
- Above 800 HP, Blown or Nitrous: Annually
- Circle Track / Endurance: each engine rebuild
- For 5.5" dampers, rebuild depends on HP:
 - 400 HP: every 5 years
 - 400-600 HP: every 2 to 3 years
 - 600+ HP: yearly

BALANCE:

Zero balance units should not be drilled and **should not** be on the crankshaft for balancing. Install the damper at engine assembly. Since the inertia weight in the Super Damper is not bonded, it may not be on center until the engine is started. The damper may show out of balance until the engine reaches 2000 RPM the first time and the inertia weight centers itself.

EXTERNAL BALANCE:

Parts #917740 and #917741E Big Block and #917080 Small Block are balanced to factory specs within one-tenth inch ounce. However, MOST engines are factory balanced with the DAMPER and FLYWHEEL installed. Dampers may have been drilled from factory specs to balance the engine at the factory. If you have the ORIGINAL damper that came on the engine OR your engine was balanced with a replacement damper installed, it is desirable to match-balance the new damper to your old unit provided the outer ring of your existing unit has not moved. When balancing external balance units, use only the hub and the weight. The inertia ring and outer shell have been factory zero balanced. **ALL OTHER EXTERNAL BALANCE UNITS ARE APPROXIMATELY 10 GRAMS HEAVY AND MUST BE BALANCED WITH YOUR ENGINE.**



Limited Warranty

Except as set forth herein, ATI Performance Products, Inc. (ATI) warrants to the original retail buyer that all products manufactured by ATI and purchased in the United States or its territories from ATI or authorized ATI dealers will be free from defects in material and workmanship. This warranty will extend for a period of 90 days from the date of the original invoice, unless otherwise agreed. ATI will repair or replace, at their option, any part, assembly or portion thereof which ATI's examination discloses to be defective. Shipping costs are not included. Disassembly by anyone other than an authorized ATI representative voids all warranties. **Use of any automatic transmission fluid or oil that is not red in color will void all warranties!** This includes all transmissions, converters, gearssets, valve bodies and all other transmission parts. **ATI MAKES NO REPRESENTATIONS OR WARRANTIES WHATSOEVER WITH RESPECT TO THE GOODS, INCLUDING BUT NOT LIMITED TO: (A) ANY WARRANTY OF MERCHANTABILITY, OR (B) ANY WARRANTY OF FITNESS FOR PARTICULAR PURPOSE WHETHER DIRECT OR INDIRECT, EXPRESS OR IMPLIED BY LAW, COURSE OF DEALING, COURSE OF PERFORMANCE, USAGE OF TRADE, OR OTHERWISE.** ATI makes no warranty as to the quality, finish, accuracy or tolerance compliance or with any safety codes required by any governmental or quasi governmental body or as to the efficiency, productivity or performance of any of the goods. There are no warranties that extend beyond the description on the face hereof.

Limited Liability

Buyer expressly agrees that in no event shall ATI be liable under any theory of recovery, whether based in contract, in tort (including negligence and strict liability), under warranty, or otherwise, for any direct, special, incidental, or consequential loss or damage whatsoever. Any loss of profits, loss of goodwill, loss of opportunity, loss of business, or loss of reputation as a result of any claim brought by buyer or third party arising out of, or relating to, any breach by ATI of these terms, any representation statement or tortious act or omission (including negligence of ATI), and any use of the goods or the failure of the goods to operate properly even if such loss was in contemplation of the parties or was wholly foreseeable. Buyer expressly agrees that in no event shall the aggregate liability of ATI under any theory of recovery exceed the aggregate price paid to ATI under these terms. The foregoing limitation shall apply even if the buyers remedies under these terms fail in their essential purpose.

THIS WARRANTY CONSTITUTES THE FULL AND FINAL ATI LIMITED WARRANTY. THERE IS NO OTHER EXPRESS WARRANTY EXCEPT AS STATED HEREIN. ANY AND ALL IMPLIED WARRANTIES OF FITNESS FOR A PARTICULAR PURPOSE AND MERCHANTABILITY ARE LIMITED IN DURATION TO THE DURATION OF THIS WARRANTY. THE LIABILITIES OF ATI ARE LIMITED SOLELY AND EXCLUSIVELY TO REPLACEMENT AS STATED HEREIN, AND DO NOT INCLUDE ANY LIABILITY FOR ANY INCIDENTAL, CONSEQUENTIAL, OR OTHER DAMAGES OF ANY KIND WHATSOEVER, WHETHER ANY CLAIM IS BASED UPON THEORIES OF CONTRACT, NEGLIGENCE, OR TORT. THIS WARRANTY GIVES YOU SPECIFIC LEGAL RIGHTS, AND YOU MAY ALSO HAVE OTHER RIGHTS WHICH VARY FROM STATE TO STATE. THERE ARE NO WARRANTIES WHICH EXTEND BEYOND THE FACE HEREOF.

This writing constitutes the full, complete, and final statement of the ATI Performance Products, Inc. Limited Warranty for Parts. All prior oral and written correspondence, test data, negotiations, representations, understandings and the like regarding Parts are merged in this writing, and extinguished by it. This Limited Warranty may not be altered, amended, extended, or modified except by a writing signed by an authorized representative of ATI. Failure at any time of ATI to enforce any of the terms and conditions stated herein shall not constitute a waiver of any of the provisions herein.

Buyer understands and agrees that no officer, director, employee, or salesman of ATI or any vendor, dealer, or distributor has any authority to make any statements contrary to the terms of this Limited Warranty. ATI disavows any statements contrary to what is above written.

Indemnify Against 3rd Party Claims

BUYER HEREBY AGREES TO INDEMNIFY, DEFEND, AND HOLD HARMLESS ATI FROM AND AGAINST ANY AND ALL CLAIMS, LIABILITY, AND LOSS AND DAMAGES (INCLUDING ATTORNEY FEES), MADE BY ANY THIRD PARTY AGAINST ATI RELATING TO A PART, OR THE USE OF ANY PART, THEREOF.

Disputes shall be construed in accordance with, and governed by, the laws of the State of Maryland, without regard to choice of law principles thereof. All disputes that may arise in connection with these Terms shall, unless settled by the parties, be submitted to arbitration in Baltimore County, Baltimore, Maryland, in accordance with the commercial arbitration rules of the American Arbitration Association. Any action by Buyer relating to the goods shall be commenced no later than one year from the date of the alleged breach.

WHO IS COVERED BY THE WARRANTY - This warranty extends to the Original Retail Purchaser only.

WHAT IS COVERED BY THIS WARRANTY - This warranty covers only ATI manufactured products. Any ATI product that, during the term of this warranty, fails to function properly UNDER NORMAL USAGE due to defects in material or workmanship will be repaired by ATI at no charge for parts or labor, or at the option of ATI, the product will be replaced.

WHAT IS NOT COVERED BY THE WARRANTY - Damages or malfunctions not resulting from defects in material and workmanship and damages or malfunctions from other than intended use including, but not limited to, improper installation, repair by unauthorized parties, tampering, modification, accident or abuse are not covered by this warranty.

KEEP THIS FOR YOUR RECORDS!

ATI recommends you retain this Warranty along with your invoice. **For your protection, fill in the information and immediately mail the Purchase Information form below so that we may contact you directly in the event a safety notification is issued.** Also, in order to serve you better, please take a moment to answer the questionnaire on the reverse side of this form. We value your comments!

ORDER #: _____

PURCHASE DATE: _____

If more than one product was purchased, list each part # separately with serial # (if applicable).

Part #: _____

Serial #: _____

Part #: _____

Serial #: _____

Part #: _____

Serial #: _____

If not purchased directly from ATI:

DEALER: _____

DEALER'S ADDRESS: _____

WHAT TO DO WHEN SERVICE IS NEEDED

Carefully package the product using ample material (preferably in the original carton) to prevent damage during shipping. **Be sure to drain any fluid left in your converter or transmission!** You may either deliver it or ship it postage prepaid and insured to ATI. Send to:

ATI PERFORMANCE PRODUCTS, INC.

Attention: Service Department

6718 Whitestone Road

Gwynn Oak, Maryland 21207-9805

Phone: (410) 298-4343 • Fax: (410) 298-3579

When returning items for service, your package must include:

- 1. A copy of the sales invoice.
- 2. Product serial number(s).
- 3. A detailed description of the problem.
- 4. Daytime and cell phone numbers plus an e-mail address where our technicians can contact you.

Note! Finished repairs must be picked up or shipped within 30 days or storage fees will occur. After 90 days, they will be subject to sale or disposal by ATI.

IF YOU HAVE QUESTIONS OR NEED HELP

If you have questions about the use or performance of your products, or if you have any questions or comments regarding service performed at ATI which has not been resolved to your satisfaction, write directly to: ATI Performance Products, Inc., Attention: Consumer Affairs Department, 6718 Whitestone Road, Gwynn Oak, MD 21207 or send an e-mail to info@atiracing.com.

This warranty gives you specific legal rights. You may also have other rights which vary from state to state.

3 WAYS TO REGISTER YOUR PRODUCT!

PRODUCT
REGISTRATION



Please fill in the Purchase Information form below and return to ATI.

- On-line: www.atiracing.com/warranty - or use QR Code here 
- E-mail: info@atiracing.com
- Mail: ATI Performance Products, Attn: Consumer Affairs, 6718 Whitestone Rd, Gwynn Oak, MD 21207

Name: _____

E-Mail: _____

Address: _____

City: _____ State: _____ Zip: _____

Phone: _____ Cell: _____

Part(s) Purchased: _____ Order #: _____

Part # _____ Serial Number / SFI # _____

Date of Purchase: _____ Purchased From: _____

Did the Seller meet your expectation: **If no, explain:**

- With service?	_____ yes	_____ no	_____
- With product knowledge?	_____ yes	_____ no	_____
- With sales help?	_____ yes	_____ no	_____

Other Comments: _____

How did you hear about ATI? _____

PUBLICATIONS YOU READ:

_____ Car Show & Cruise Guide	_____ Hot Rod
_____ D-Sport	_____ National Dragster (NHRA)
_____ Diesel World	_____ Performance Racing Industry
_____ Drag Illustrated	_____ RPM Magazine
_____ Drag Review (IHRA)	_____ Street Scene (NSRA)
_____ Drive!	_____ Other: _____
_____ Fastest Street Car	_____
_____ Grassroots Motorsports	_____

CHECK ALL THAT APPLY:

Section 1

_____ Drag Race	_____ Oval Track	_____ Street Performance
_____ Truck/Tractor	_____ Marine Use	_____ Other _____

Section 2

_____ GM	_____ Ford	_____ Chrysler	_____ Import
_____ Other _____			

Section 3

_____ Vehicle Owner	_____ Do-It-Yourself	_____ Professional Mechanic
_____ Shop Owner	_____ Engine Builder	_____ Race Car Builder
_____ Transmission Builder	_____ Other _____	

WEBSITES & FORUMS:

_____ Facebook	_____ Engine Labs
_____ Instagram	_____ Ford NXT
_____ YouTube	_____ LSX Mag
_____ Chevy Hardcore	_____ RacingJunk.com
_____ ClassRacer.com	_____ Street Muscle
_____ Competition Plus	_____ Other: _____
_____ DragRaceResults.com	_____
_____ DragtimeNews.com	_____
_____ Dragzine	_____